



A3 Rotary Drum Screens

www.a3-usa.com

Wastewater Equipment

A3 Rotary Drum Screen

The A3 rotary drum screen is an in-channel screen for use in high capacity applications

The wedge wire drum screen has stationary cleaning brushes. The screen is coupled to an independently-driven discharge auger complete with a compaction zone and vertical discharge chute.

Flow is directed to the internal surface of the drum that resides in the channel. As solids blind the drum screen, the water level increases and activates the discharge screw motor. The solids are transported by the auger where they are further compacted and dried and transported to the vertical discharge. This allows drying to 25-35% solids.

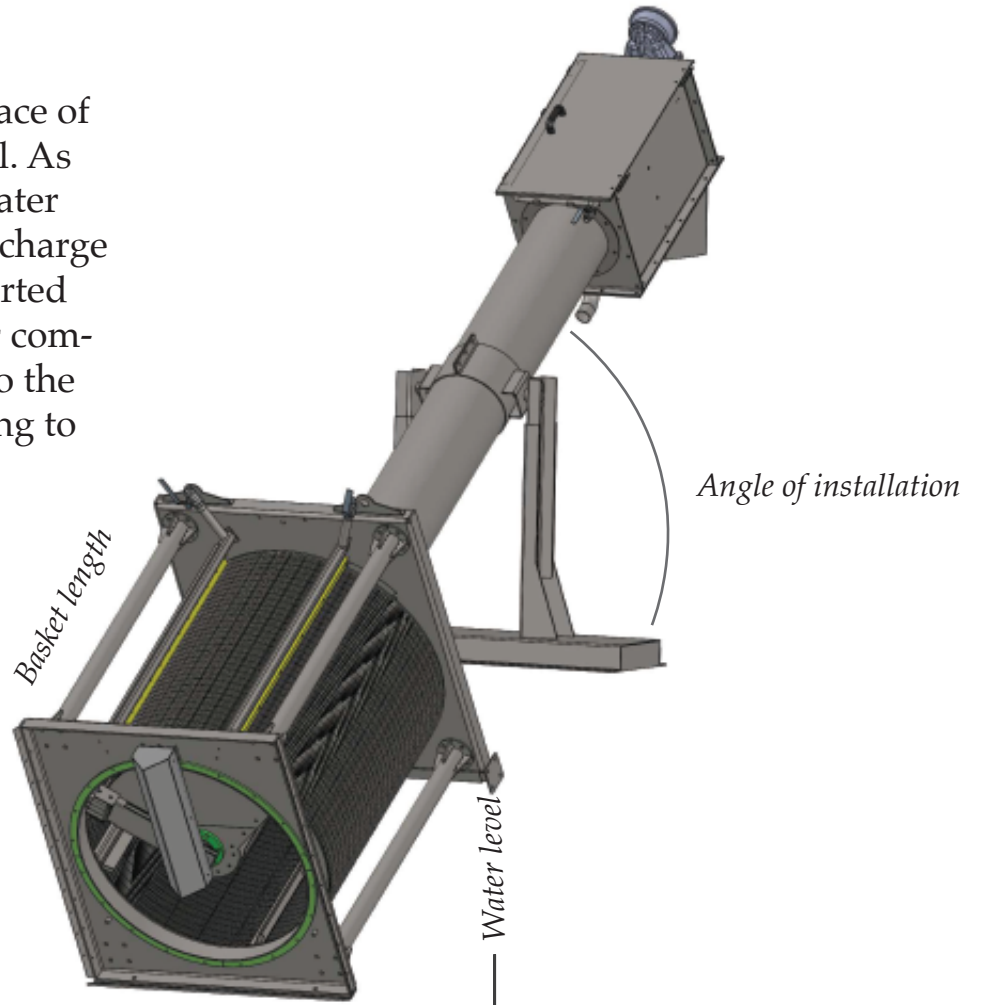

Channel width

Model	1	2	3	4	5	6	7	8	9
Channel width	31	39	47	55	63	71	79	94	102
Basket length	31	39	47	55	63	71	79	94	102
Water level	23	30	37	41	47	55	63	79	83
Angle installation	35°	35°	35°	35°	35°	35°	35°	35°	35°

All dimensions in inches; custom sizes also available

A3 Rotary Drum Screen

- Automated operation
- Enclosure minimizes odor
- Easy access using removable covers
- Fabricated from AISI 304 or 316
- .5-2mm wedgewire screening sizes
- Up to 45 MGD theoretical flow rate

Easy access using
removable cover

Screenings discharge
to press or dumpster

Screen pivots out
of channel

Wedgewire & bar
screen options



A3 Rotary Drum Screen - Photos

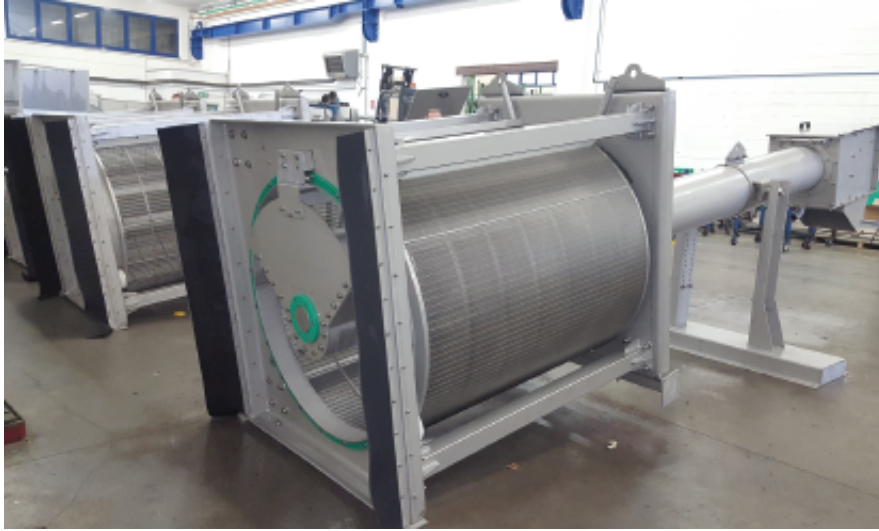

Rotary drum screen with wedgewire



Rotary drum screen with bars



Rotary drum screen



Rotary drum screen

